

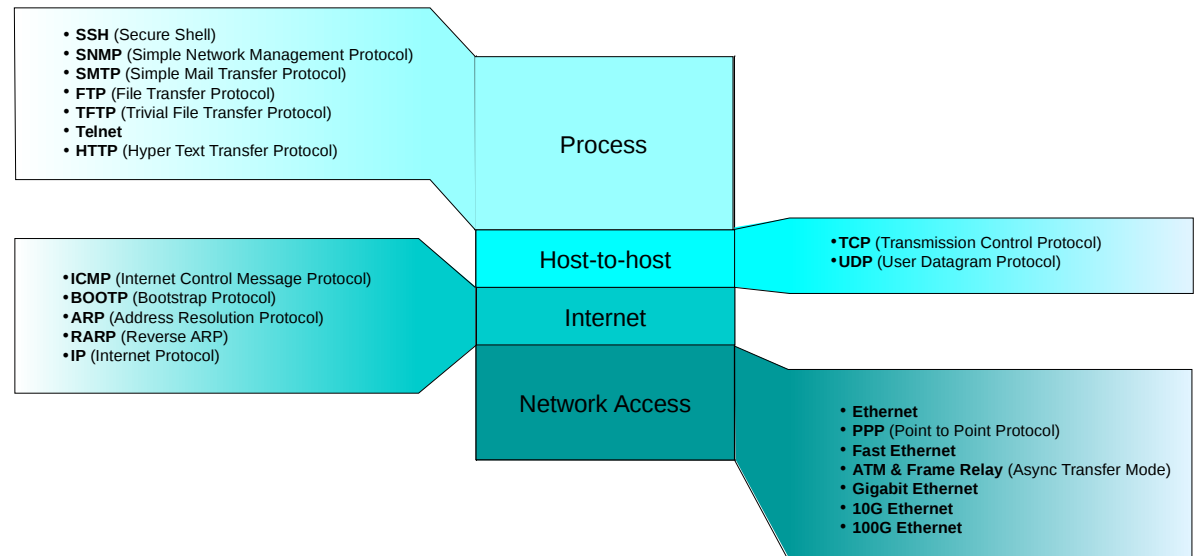

# CMP4204 Wireless Technologies

## Lecture 4

# Internetworking models and Networking



**Diarmuid Ó Briain**

CEng, FIEI, FIET, CISSP

diarmuid@obriain.com

# Internetworking Models - OSI



OSI  
Layer

7	Application	File, Print, database & Application services
6	Presentation	Data encryption, compression & translation services
5	Session	Dialogue control
4	Transport	End to End connection
3	Network	Routing
2	Data Link	Framing, Bridging, Switching
1	Physical	Physical network topology

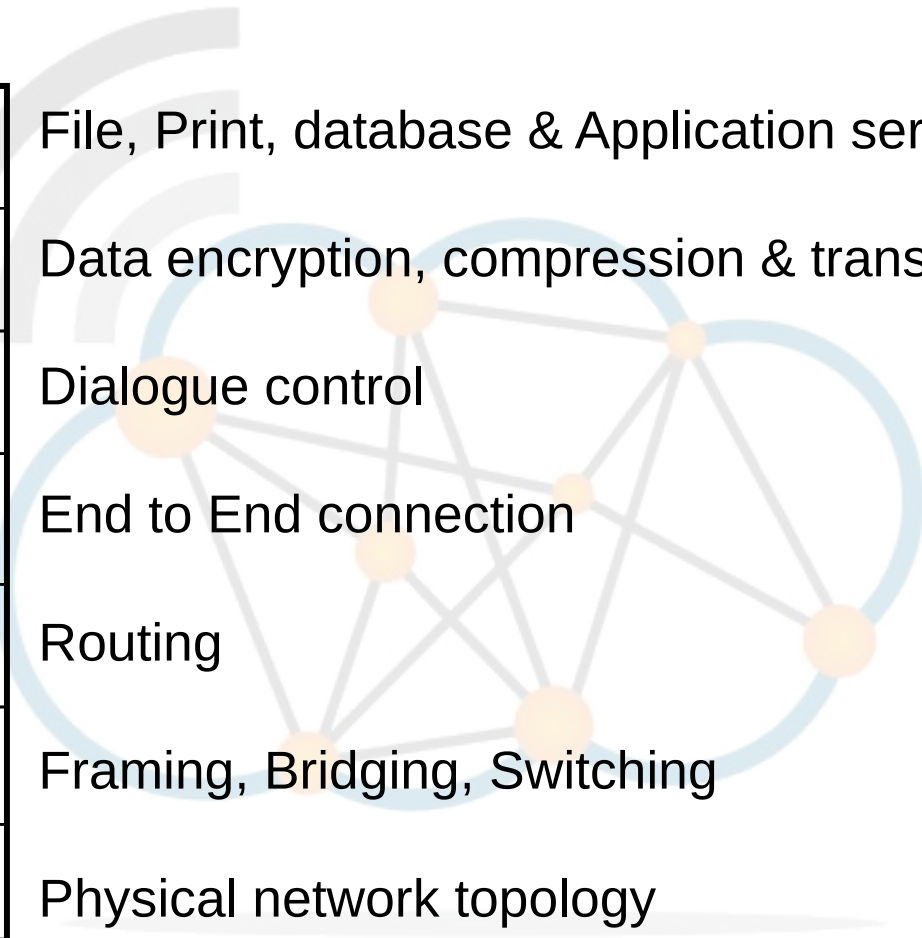

# Internetworking Models - OSI

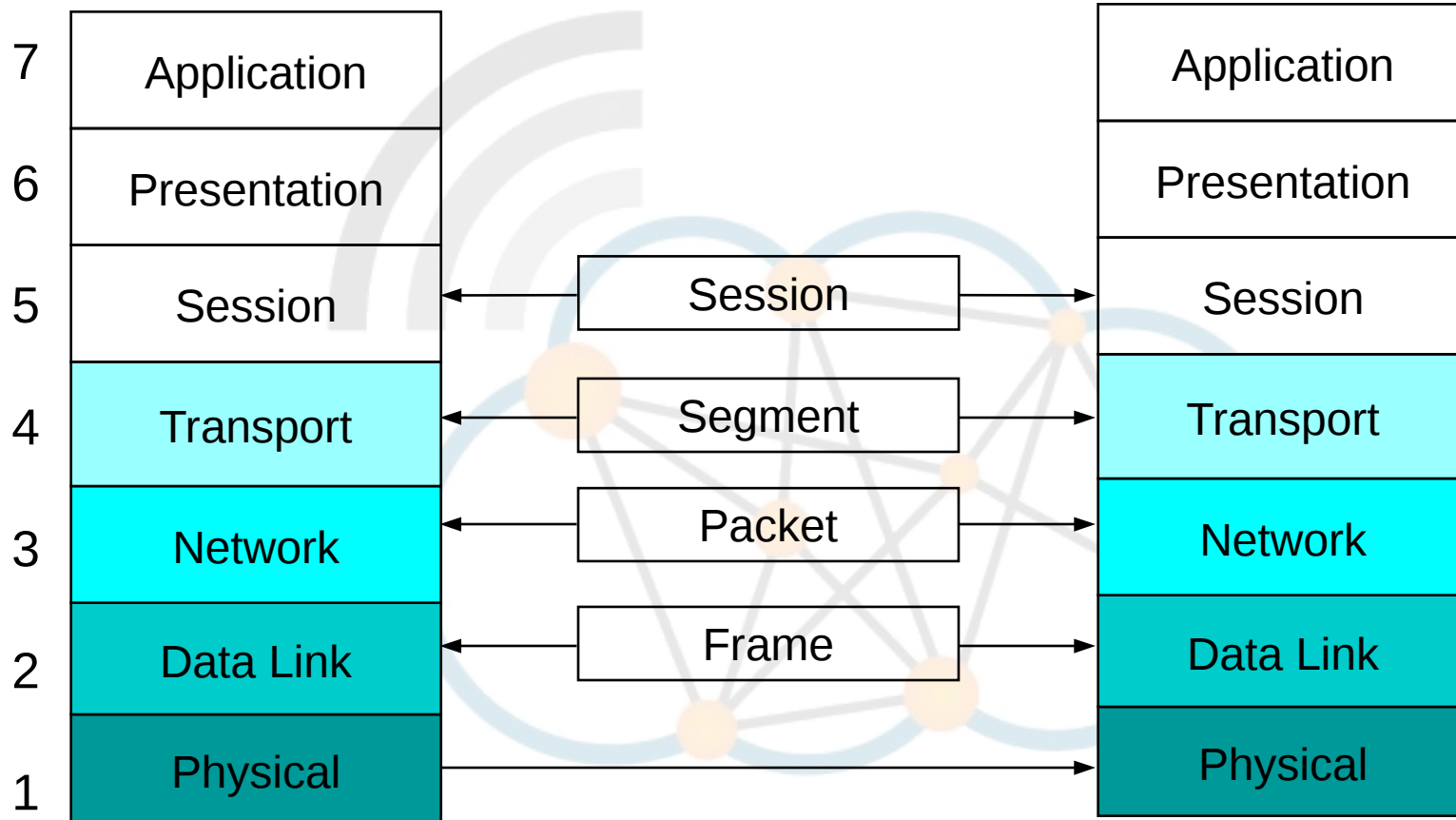

# Internetworking Models - OSI

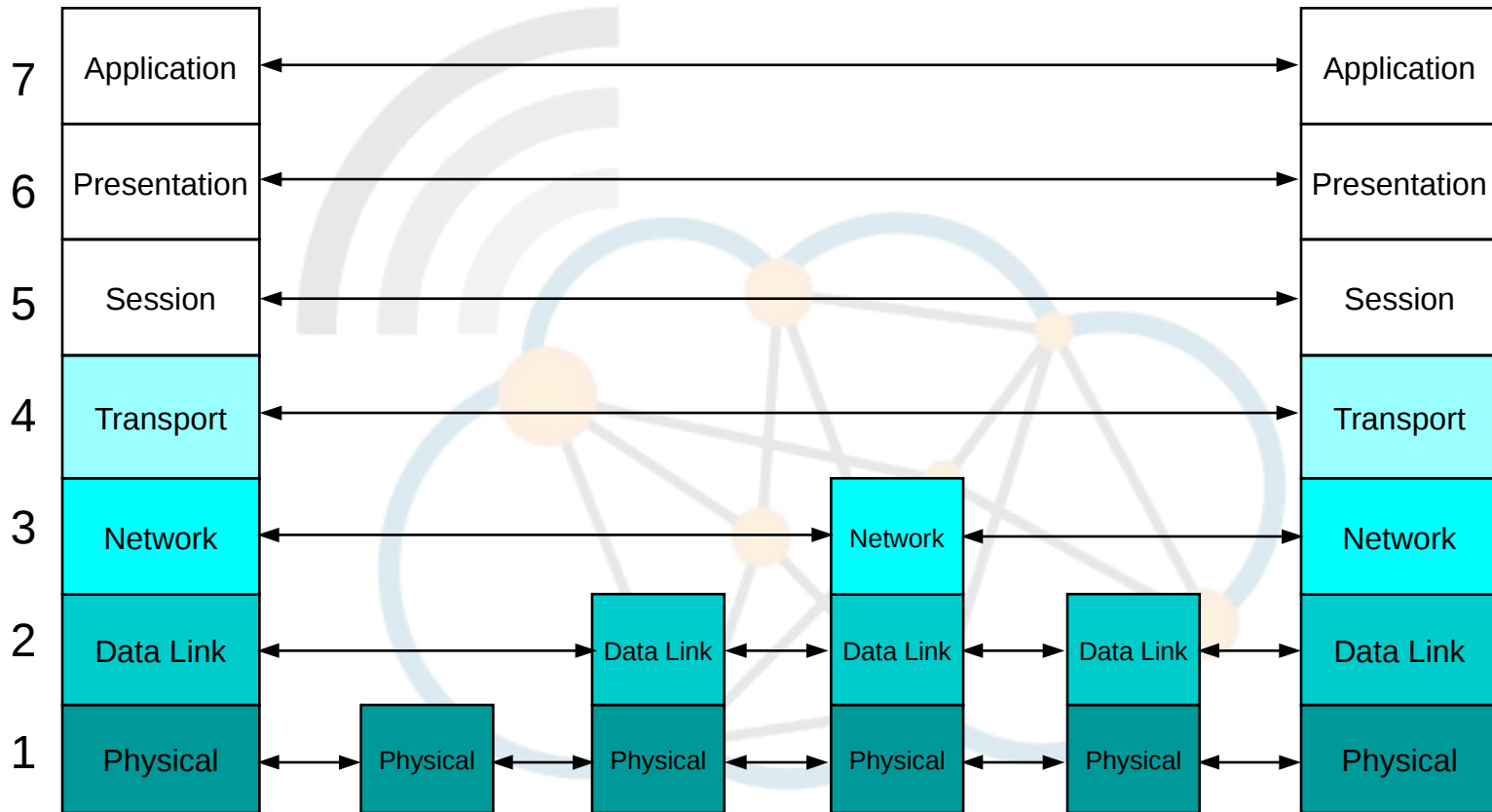

# DoD Networking Model (TCP/IP)



- The DoD Four-Layer Model was developed in the 1970s for the DARPA Internetwork Project that eventually grew into the Internet.
- The four layers in the DoD model:
  - The **Network Access Layer** is responsible for delivering data over the particular hardware media in use. Different protocols are selected from this layer, depending on the type of physical network.
  - The **Internet Layer** is responsible for delivering data across a series of different physical networks that interconnect a source and destination machine. Routing protocols are most closely associated with this layer, as is the IP Protocol, the Internet's fundamental protocol.
  - The **Host-to-Host Layer** handles connection rendezvous, flow control, retransmission of lost data, and other generic data flow management. The mutually exclusive TCP and UDP protocols are this layer's most important members.
  - The **Process Layer** contains protocols that implement user-level functions, such as mail delivery, file transfer and remote login.

# DoD Networking Model (TCP/IP)

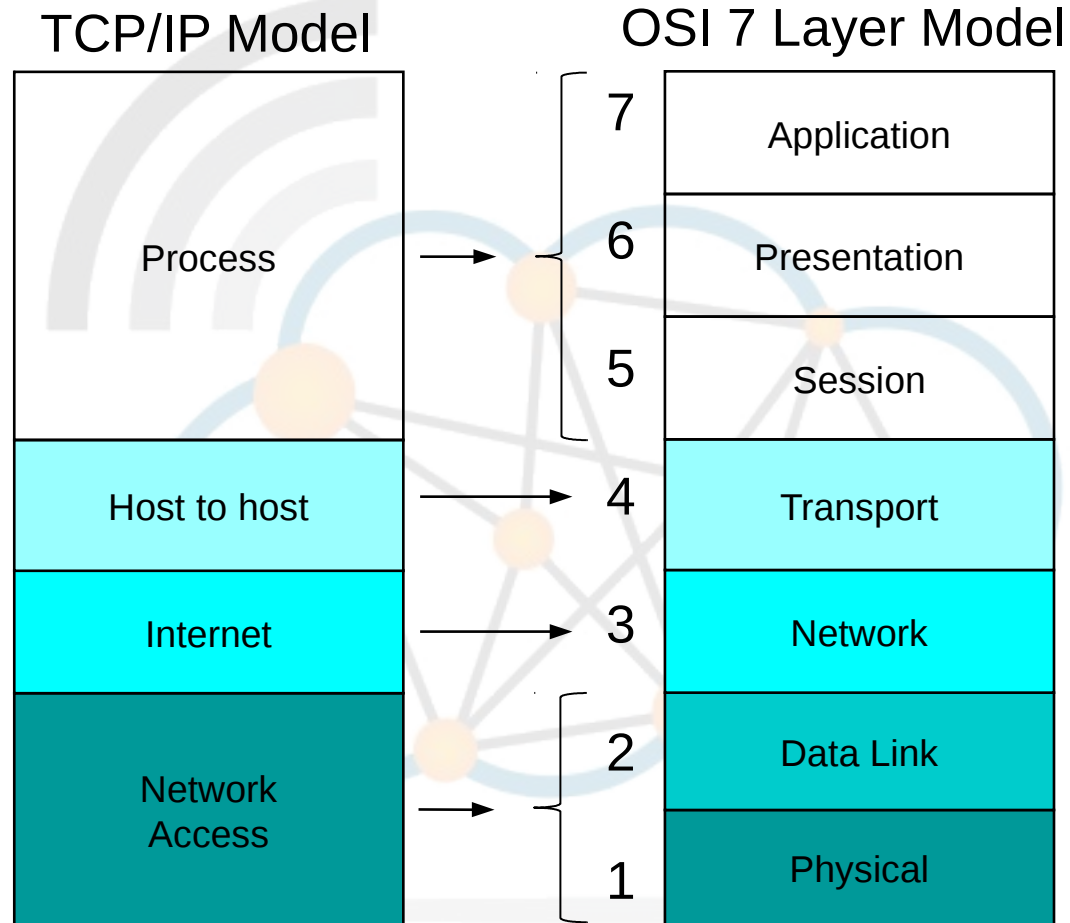

# Network Access Protocols

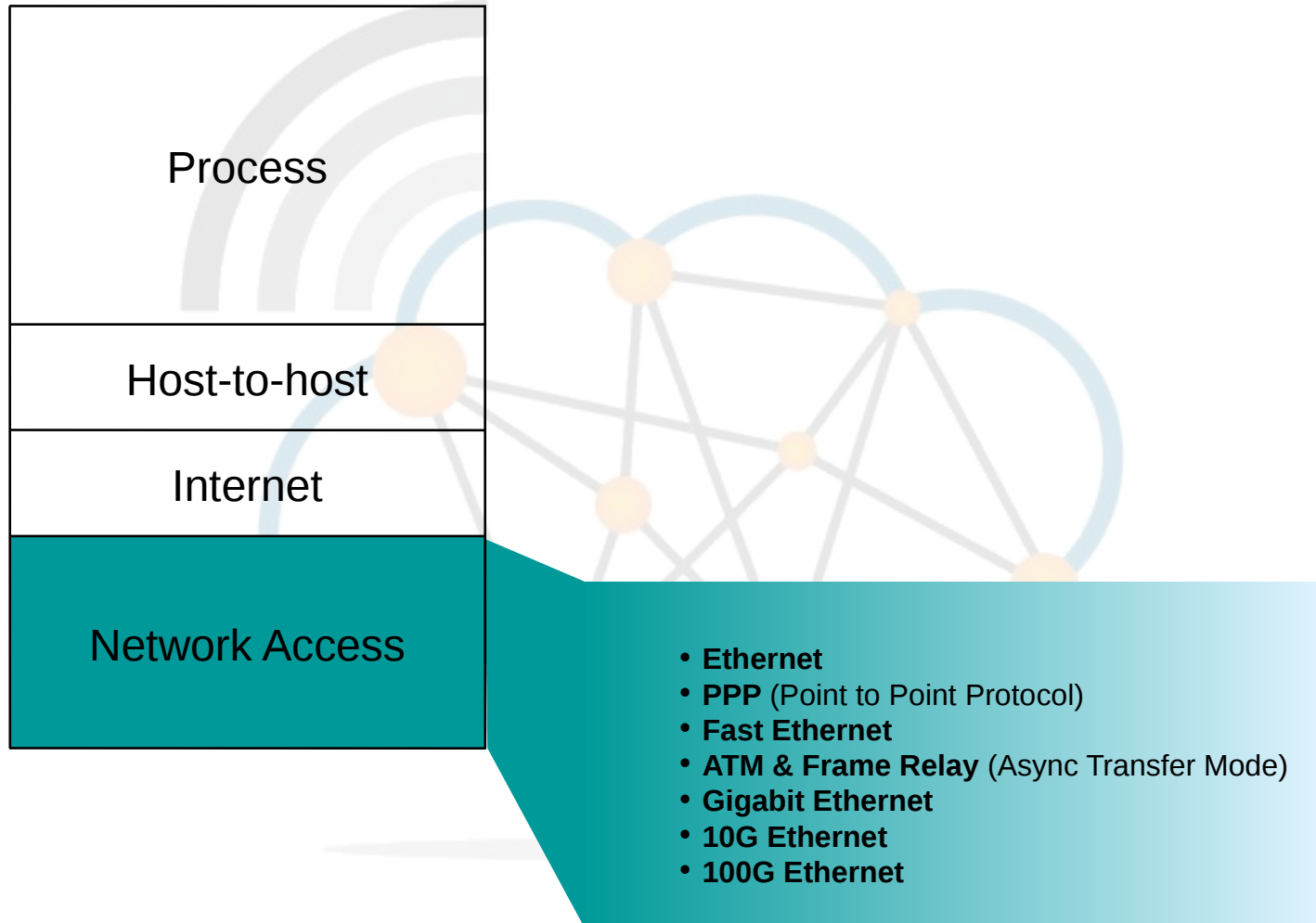

# Internet Protocols

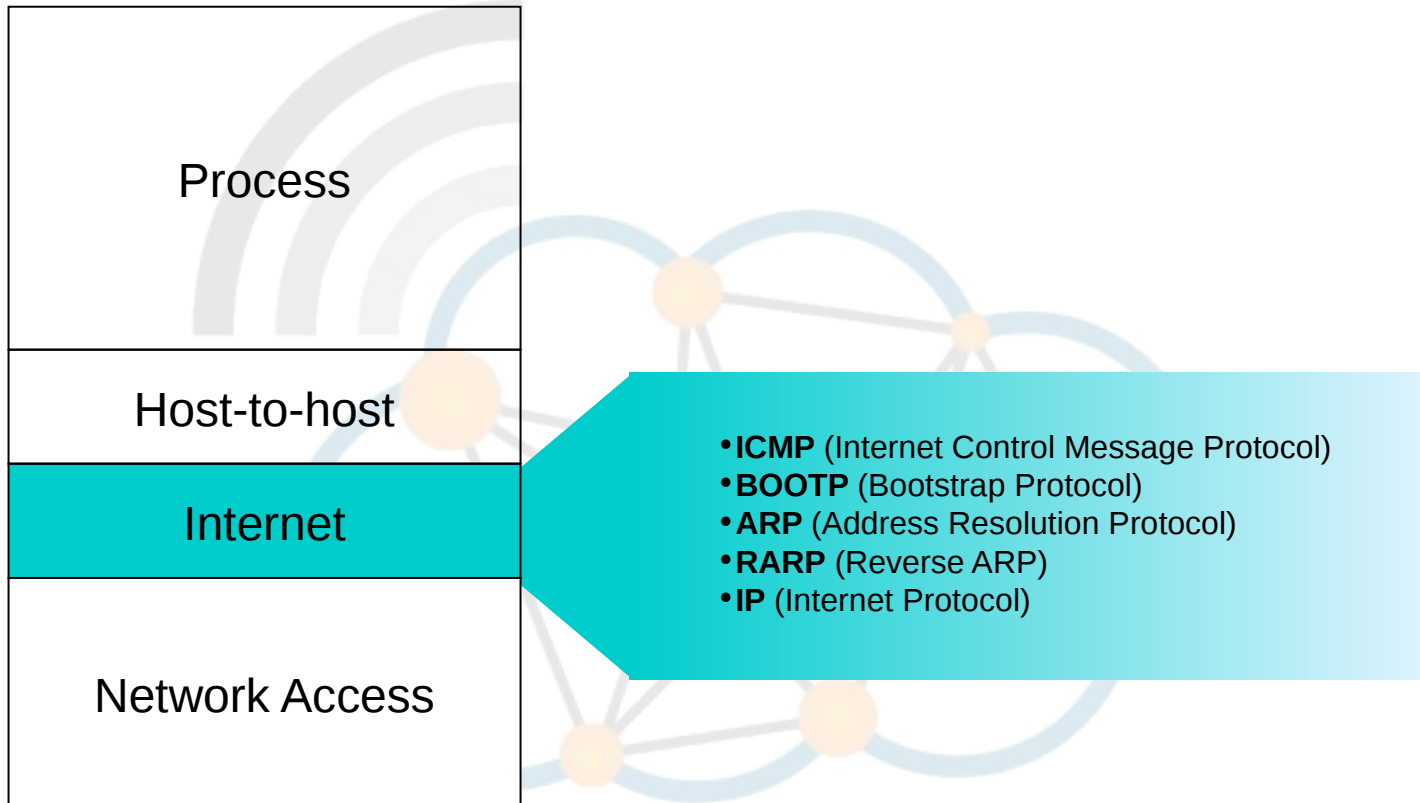



# Internet Protocols

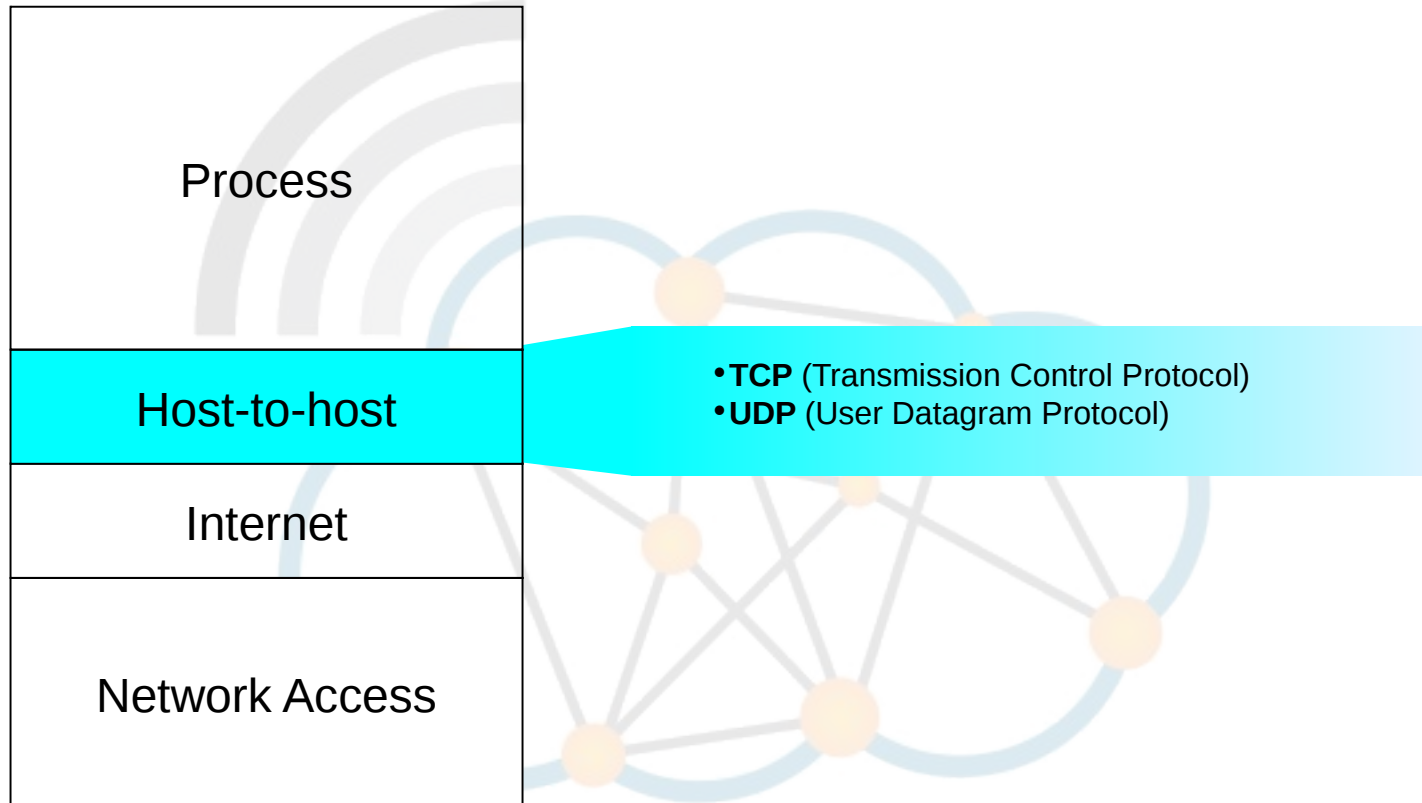

# Application Protocols

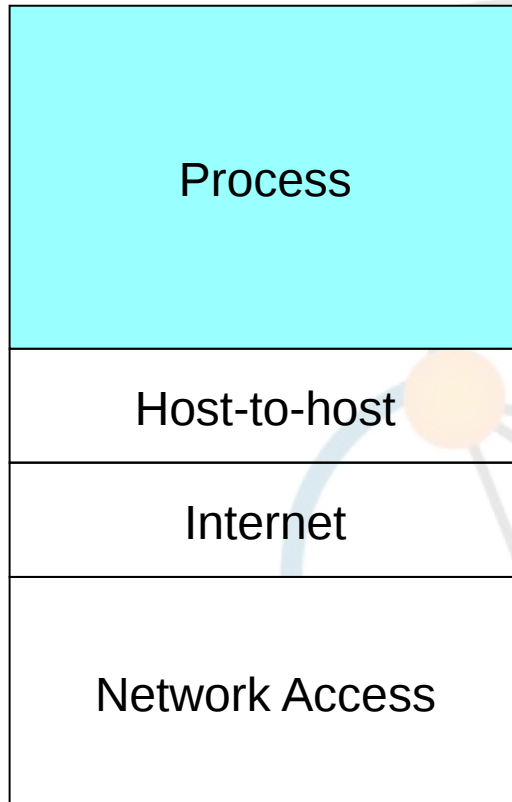

- **SSH** (Secure Shell)
- **SNMP** (Simple Network Management Protocol)
- **SMTP** (Simple Mail Transfer Protocol)
- **FTP** (File Transfer Protocol)
- **TFTP** (Trivial File Transfer Protocol)
- **Telnet**
- **HTTP** (Hyper Text Transfer Protocol)

# Application Protocols

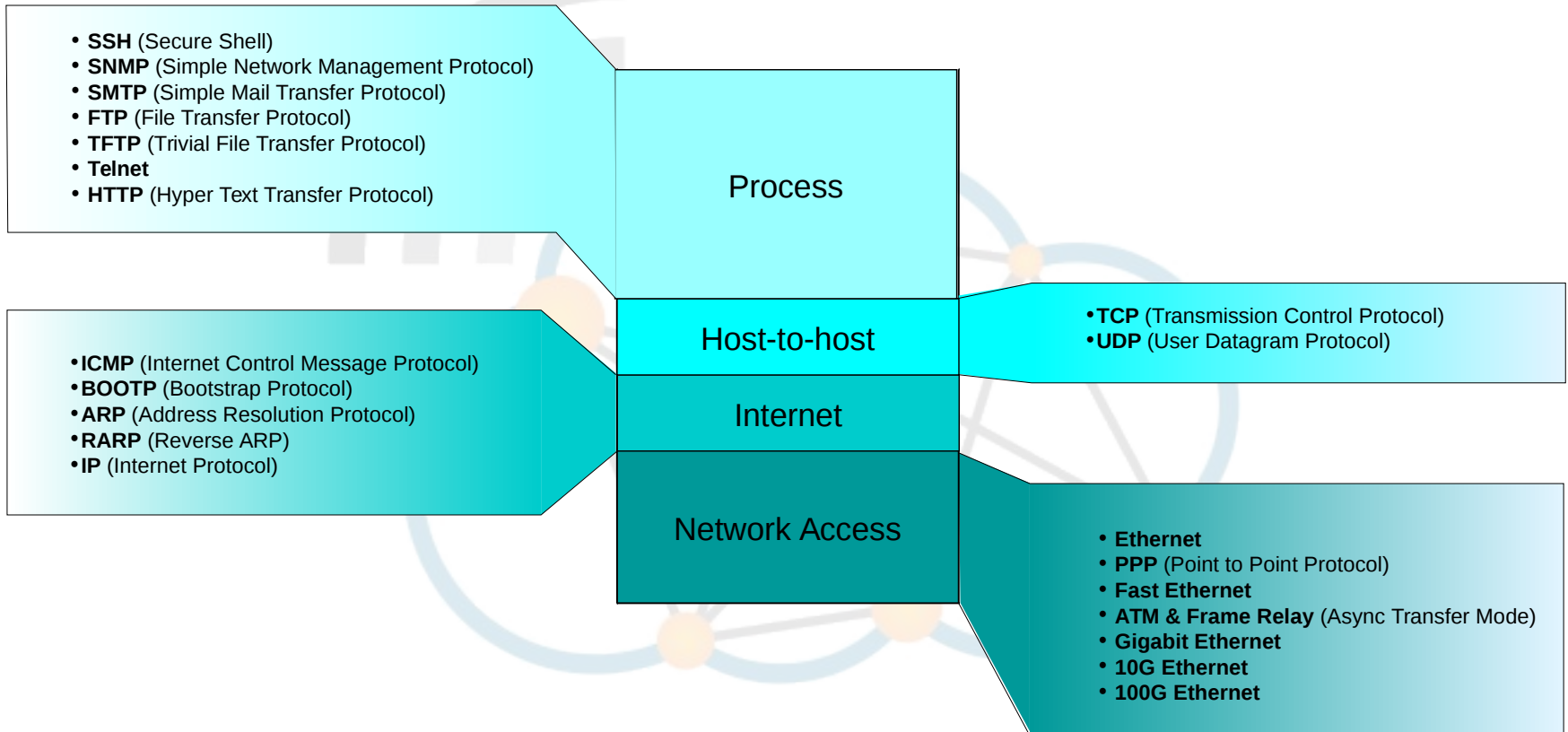

# Internetworking Model

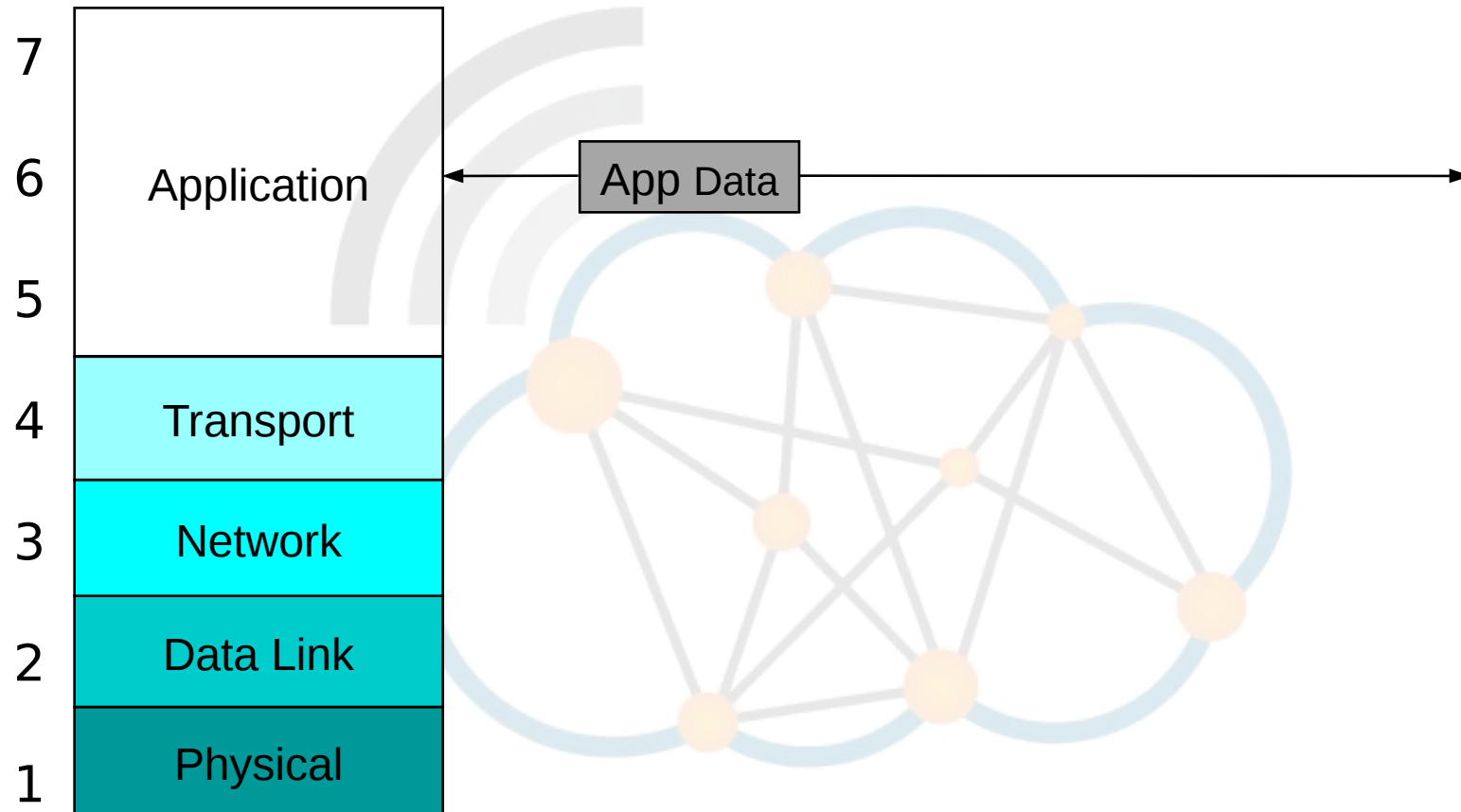

# Internetworking Model

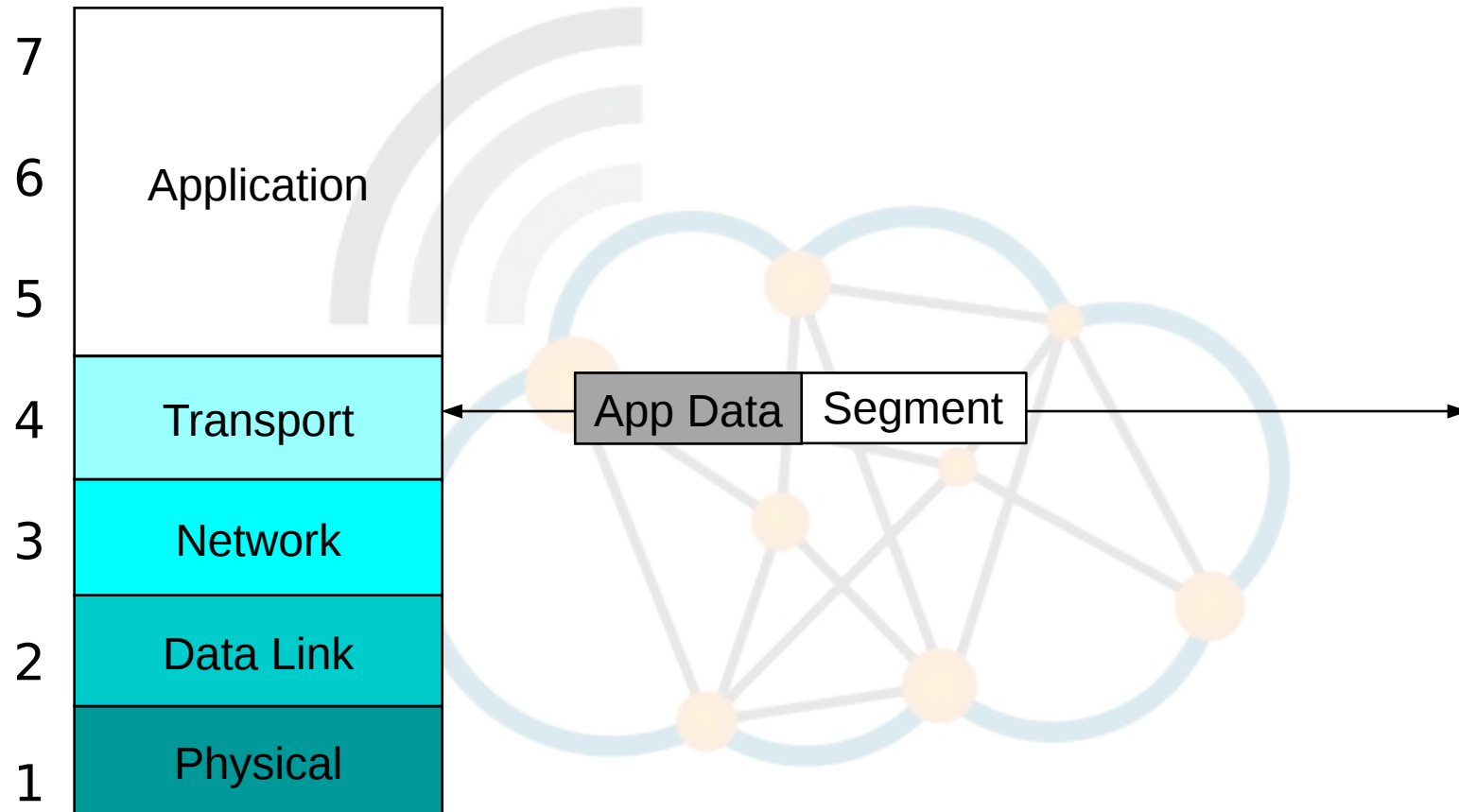

# Internetworking Model

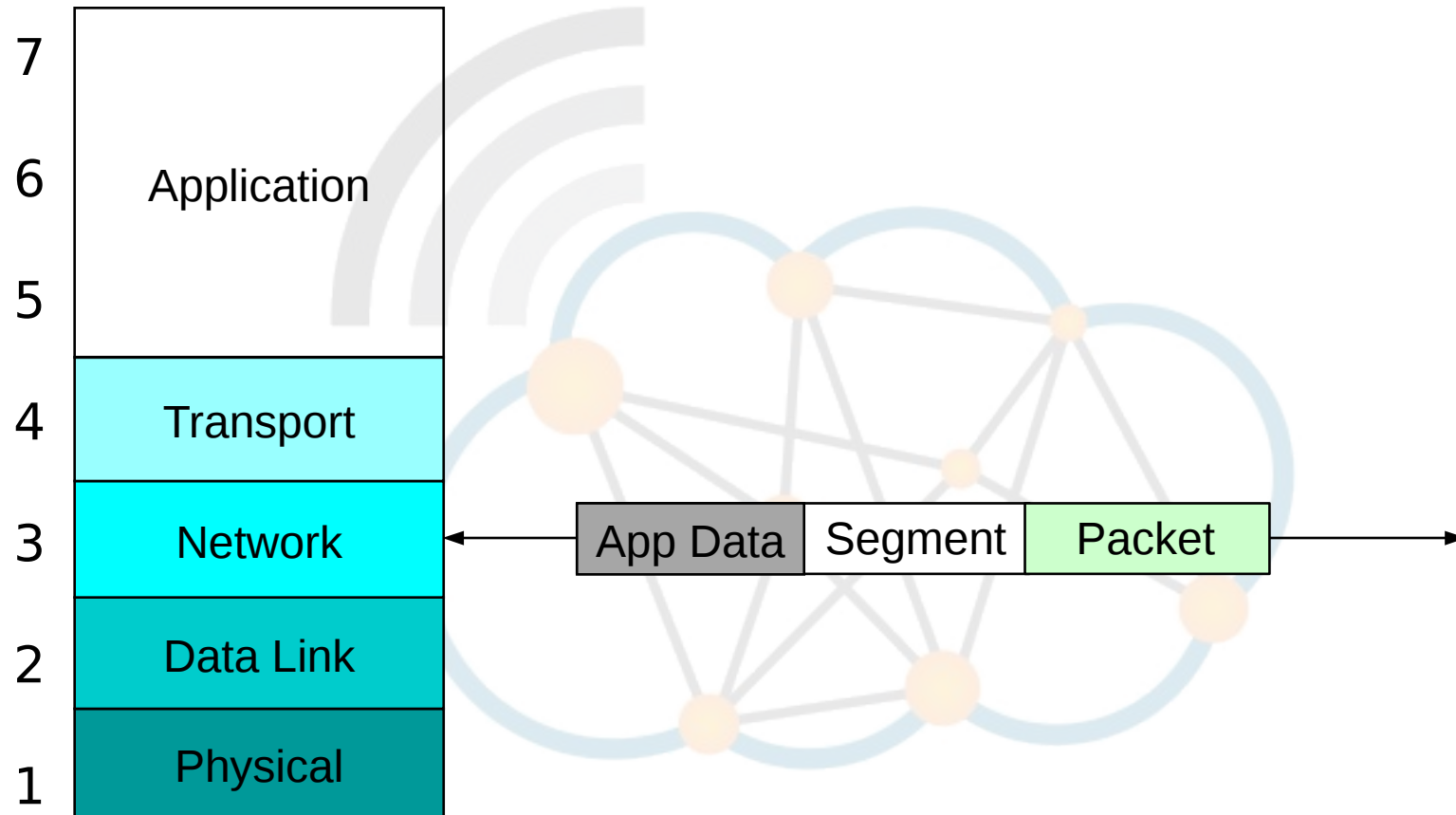

# Internetworking Model

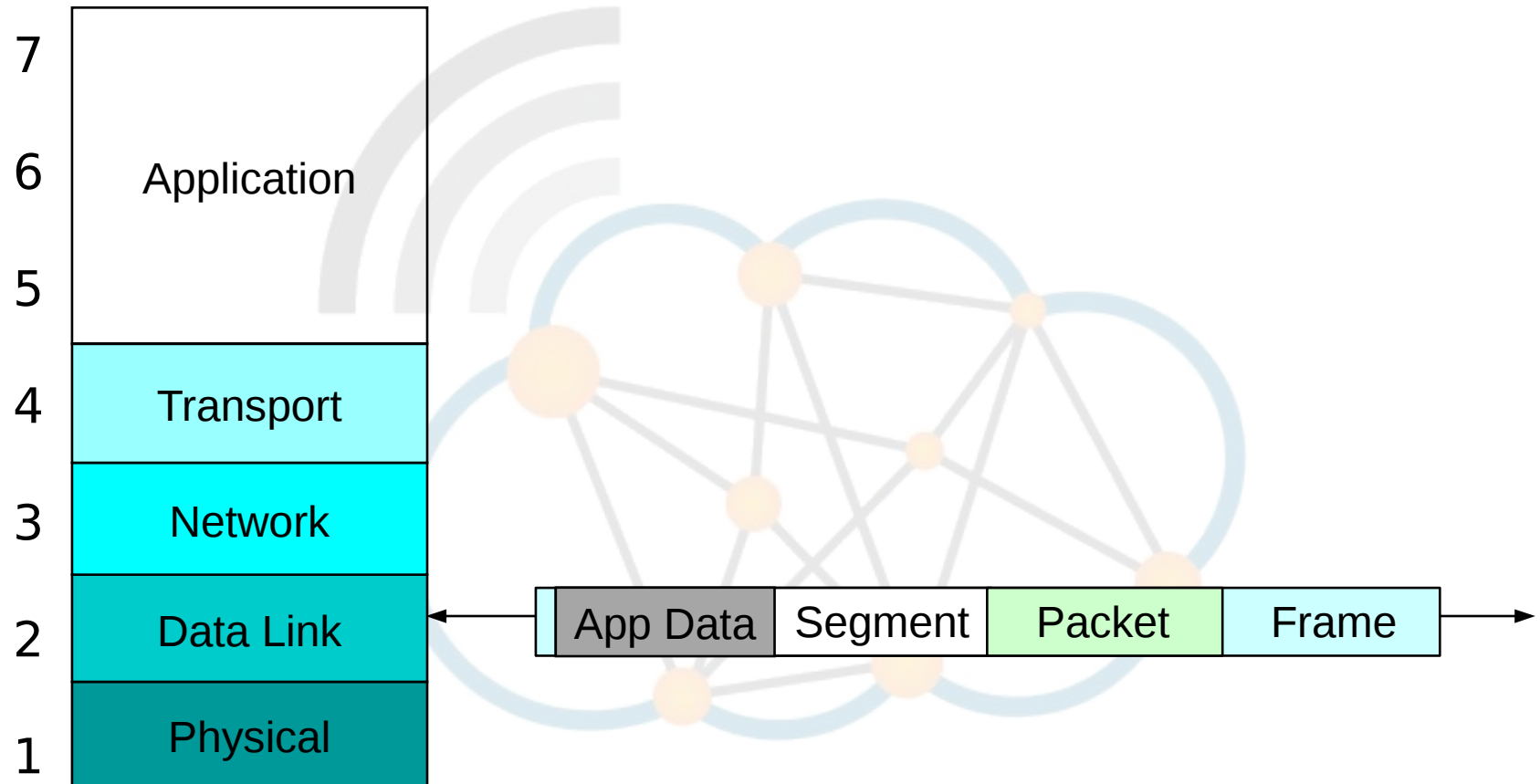

# Internetworking Model

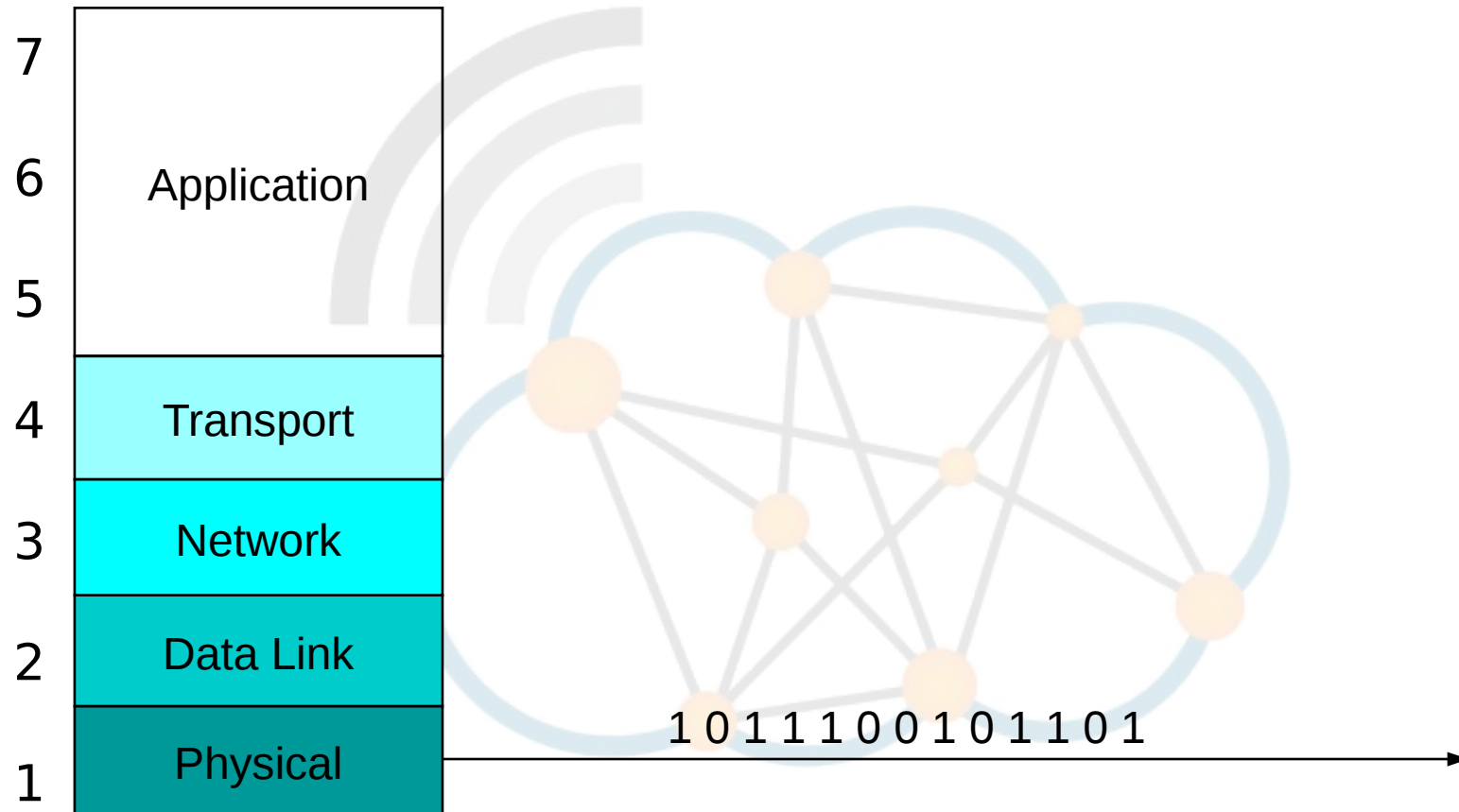



# Internetworking Model

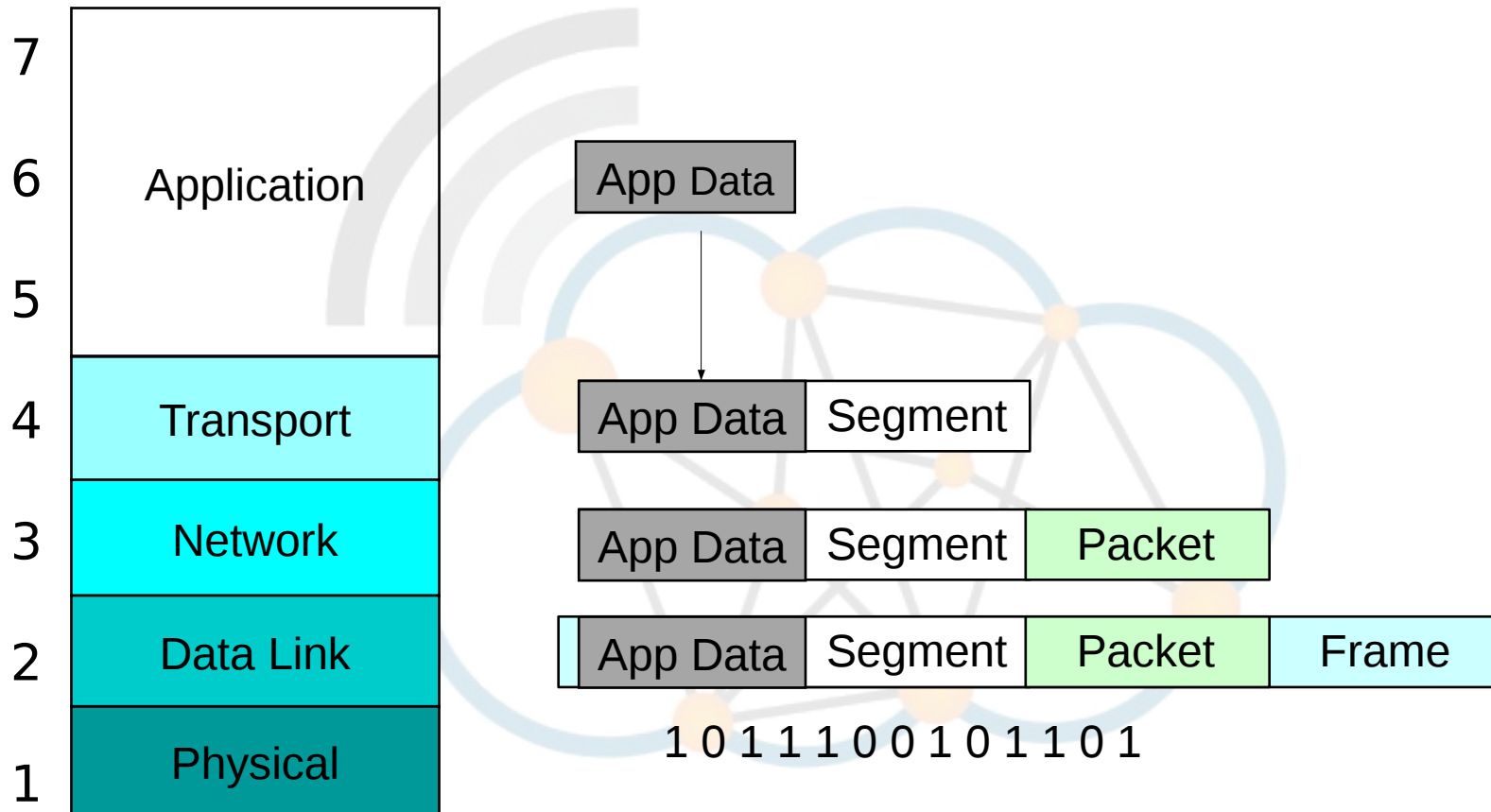

# MAC Address

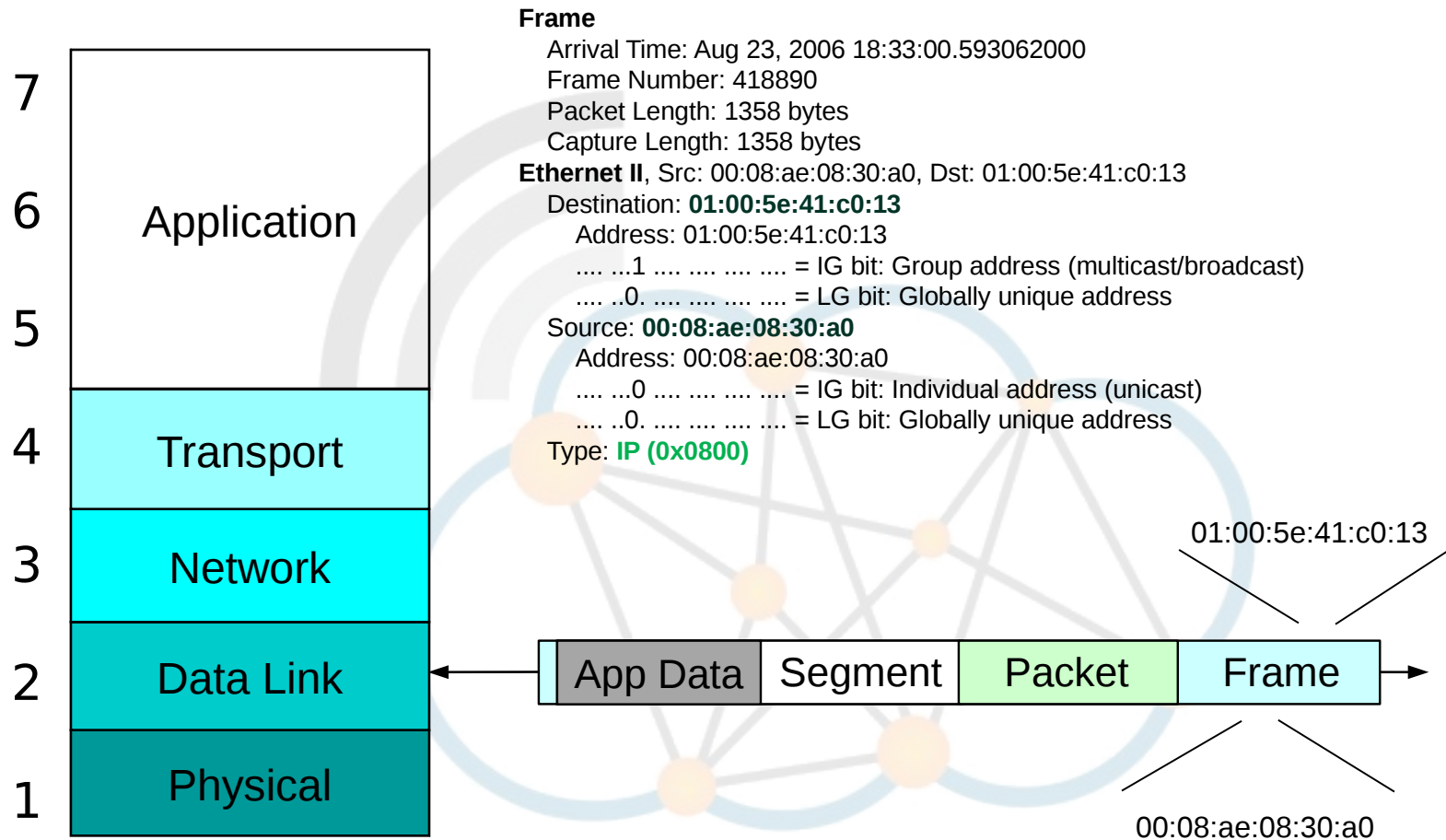

- Media Access Control address (MAC address) is a unique ID attached to most NICs.
- It is a number that acts like a name for a particular NIC.

# MAC Address

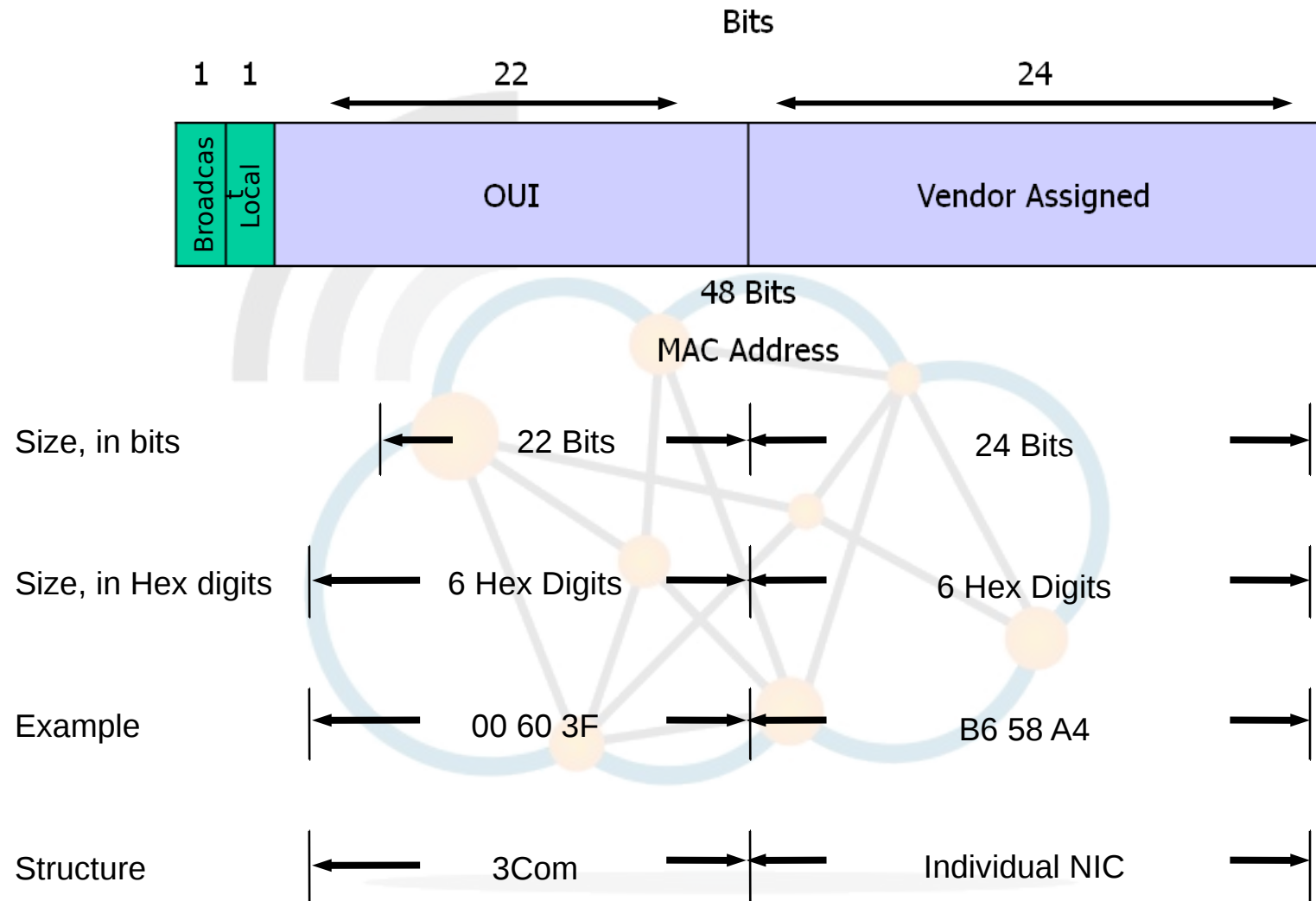



- So the address used in an Ethernet LAN is the means by which data is directed to the proper receiving location, the address is associated with the network adaptor otherwise known as the NIC. The NIC has a unique address burned onto it called the MAC address.
- The address that is on the NIC is the MAC address (Media Access Control) – often referred to as the Burned In Address (BIA).

# IP Address

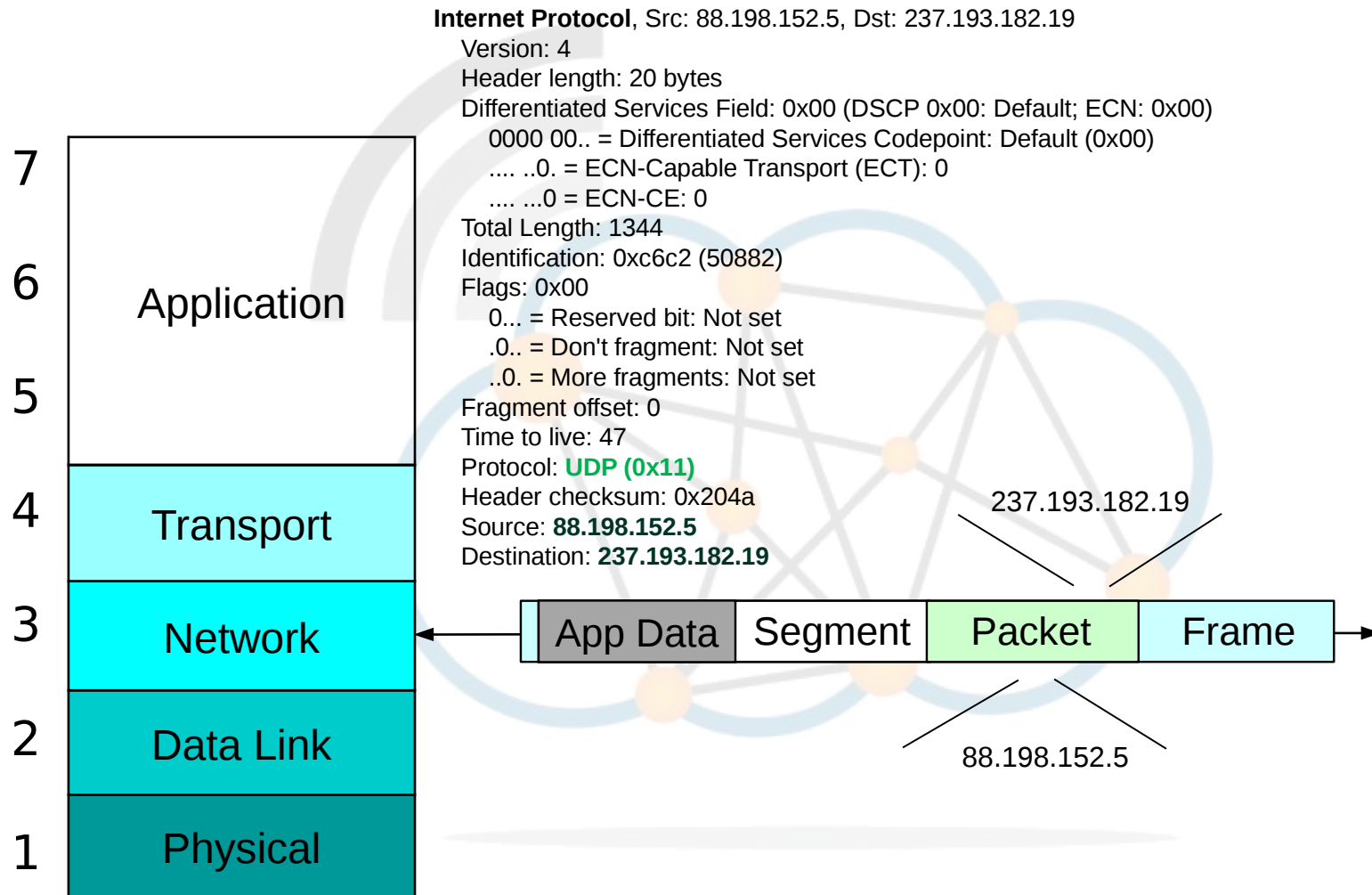

# Port Number - UDP

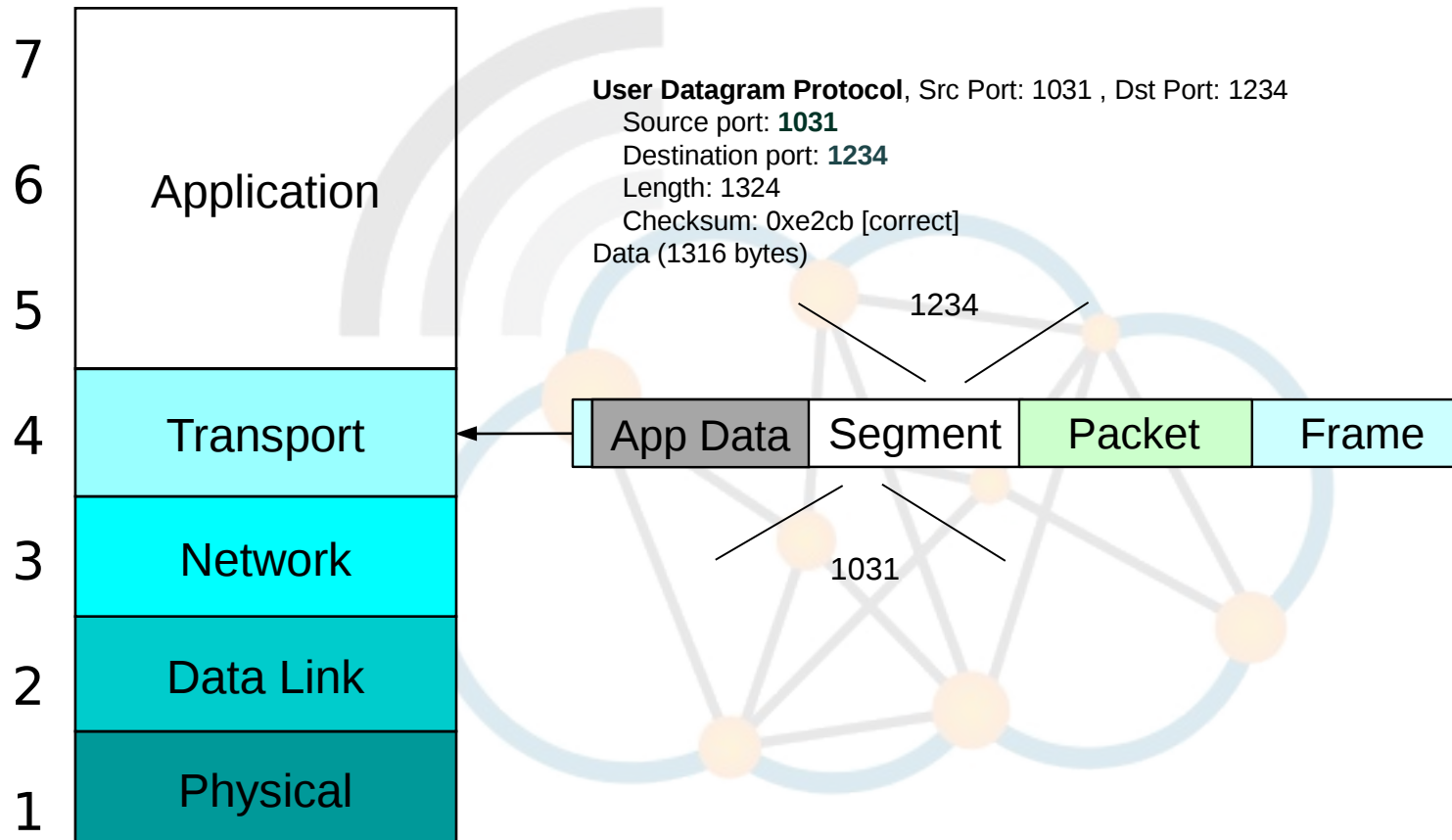

# Port Number - TCP



**Transmission Control Protocol**, Src Port: 1025 , Dst Port: 143, Seq: 1019, Ack: 9456, Len: 35

Source port: **1025**

Destination port: **143 (imap)**

Sequence number: **1019** (relative sequence number)

[Next sequence number: 1054 (relative sequence number)]

Acknowledgement number: 9456 (relative ack number)

Header length: 20 bytes

Flags: 0x18 (PSH, ACK)

0... .... = Congestion Window Reduced (CWR): Not set

.0.. .... = ECN-Echo: Not set

..0. .... = Urgent: Not set

...1 .... = Acknowledgment: Set

.... 1... = Push: Set

.... .0.. = Reset: Not set

.....0. = Syn: Not set

.....0 = Fin: Not set

Window size: 64311

Checksum: 0x20bf [incorrect, should be 0xb4a6 (maybe caused by checksum offloading?)]

[SEQ/ACK analysis]

[This is an ACK to the segment in frame: 214]

[The RTT to ACK the segment was: 0.000231000 seconds]

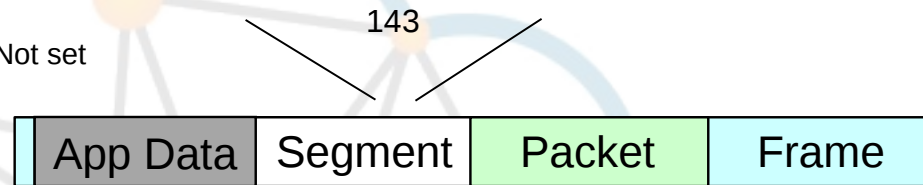

# Address Resolution Protocol



```
C:\>arp -a
```

```
Interface: 192.168.0.2 --- 0x8
```

Internet Address	Physical Address	Type
192.168.0.1	00-18-4d-0d-20-9c	dynamic
192.168.0.255	ff-ff-ff-ff-ff	static
224.0.0.22	01-00-5e-00-00-16	static
239.255.255.250	01-00-5e-7f-ff-fa	static

```
C:\>arp -av
```

```
Interface: 127.0.0.1 --- 0x1
```

Internet Address	Physical Address	Type
224.0.0.22	static	
239.255.255.250	static	

```
Interface: 192.168.0.2 --- 0x8
```

Internet Address	Physical Address	Type
192.168.0.1	00-18-4d-0d-20-9c	dynamic
192.168.0.2	00-00-00-00-00-00	invalid
192.168.0.255	ff-ff-ff-ff-ff	static
224.0.0.22	01-00-5e-00-00-16	static
239.255.255.250	01-00-5e-7f-ff-fa	static



# Address Resolution Protocol

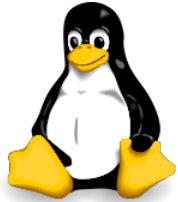

```
Linux :~ # arp
```

Address	HWtype	HWaddress	Flags	Mask	Iface
10.10.10.10	ether	00:08:A1:7A:F4:82	C		eth1
172.27.228.163	ether	00:0D:56:05:18:5F	C		eth0
172.27.228.70	ether	00:0D:56:98:31:C6	C		eth0
172.27.228.157	ether	00:11:43:A3:0B:D4	C		eth0
172.27.228.158	ether	00:0F:1F:E0:36:D9	C		eth0
172.27.228.69	ether	00:11:43:20:3A:F7	C		eth0
172.27.228.1	ether	00:0D:65:53:3F:C2	C		eth0
172.27.228.150	ether	00:0D:56:05:18:53	C		eth0

```
Linux :~ # arp -v
```

Address	HWtype	HWaddress	Flags	Mask	Iface
10.10.10.10	ether	00:08:A1:7A:F4:82	C		eth1
172.27.228.163	ether	00:0D:56:05:18:5F	C		eth0
172.27.228.70	ether	00:0D:56:98:31:C6	C		eth0
172.27.228.157	ether	00:11:43:A3:0B:D4	C		eth0
172.27.228.158	ether	00:0F:1F:E0:36:D9	C		eth0
172.27.228.69	ether	00:11:43:20:3A:F7	C		eth0
172.27.228.1	ether	00:0D:65:53:3F:C2	C		eth0
172.27.228.150	ether	00:0D:56:05:18:53	C		eth0

Entries: 8 — Skipped: 0 — Found: 8

# Domain Name Service (DNS)

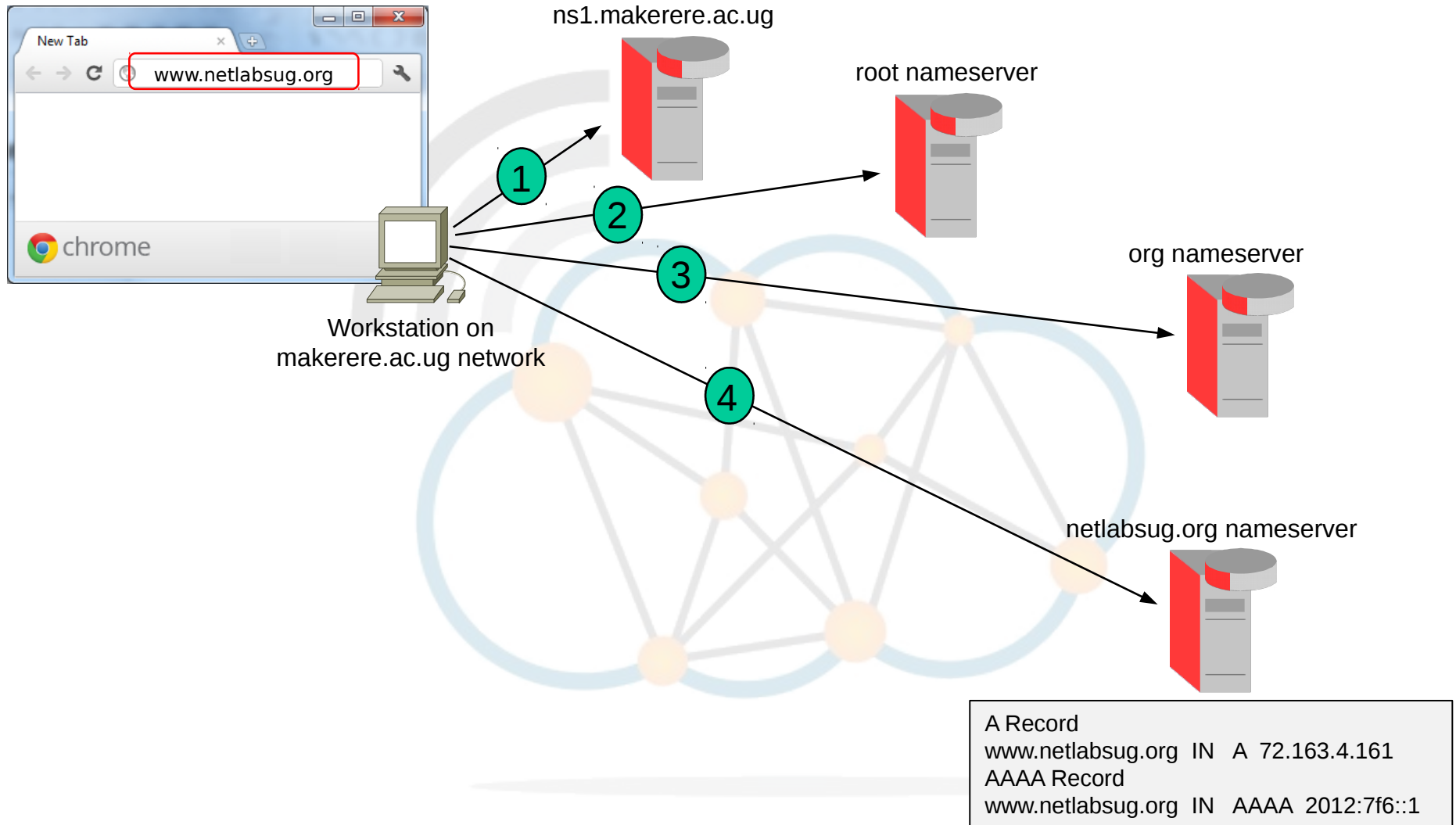

# Protocol Mapping



Layer	Name	TCP/IP	SS 7	OSI	UMTS
7	Application	HTTP, RIP, SMTP, SMPP, SNMP, FTP, Telnet, NFS, NTP, RTP	ISUP, INAP, MAP, TUP, TCAP	FTAM, X.400, X.500, DAP	
6	Presentation	MIME, XDR, SSL, TLS		ISO 8823, X.226	
5	Session			ISO 8327, X.225	
4	Transport	TCP, UDP, SCTP		TP0, TP1, TP2, TP3, TP4	
3	Network	IP, ICMP, IPsec, ARP, BGP, OSPF	MTP-3, SCCP	X.25, CLNP	RRC
2	Data Link	Ethernet, 802.2, 802.3, 802.5, 802.11, 802.14, 802.16, PPP, HDLC	MTP-2	X.25 (LAP-B)	MAC
1	Physical	RS-232, V.35, V.34, E1, T1, 10BASE-T, 100BASE-TX, 802.11, 802.15, 802.16, DSL, DOCSIS	MTP-1	X.25, EIA/TIA-232, EIA/TIA-449, EIA-530, G.703	PHY



## Networking Lab

**Diarmuid Ó Briain**

CEng, FIEI, FIET, CISSP

diarmuid@obriain.com

# Networking Lab

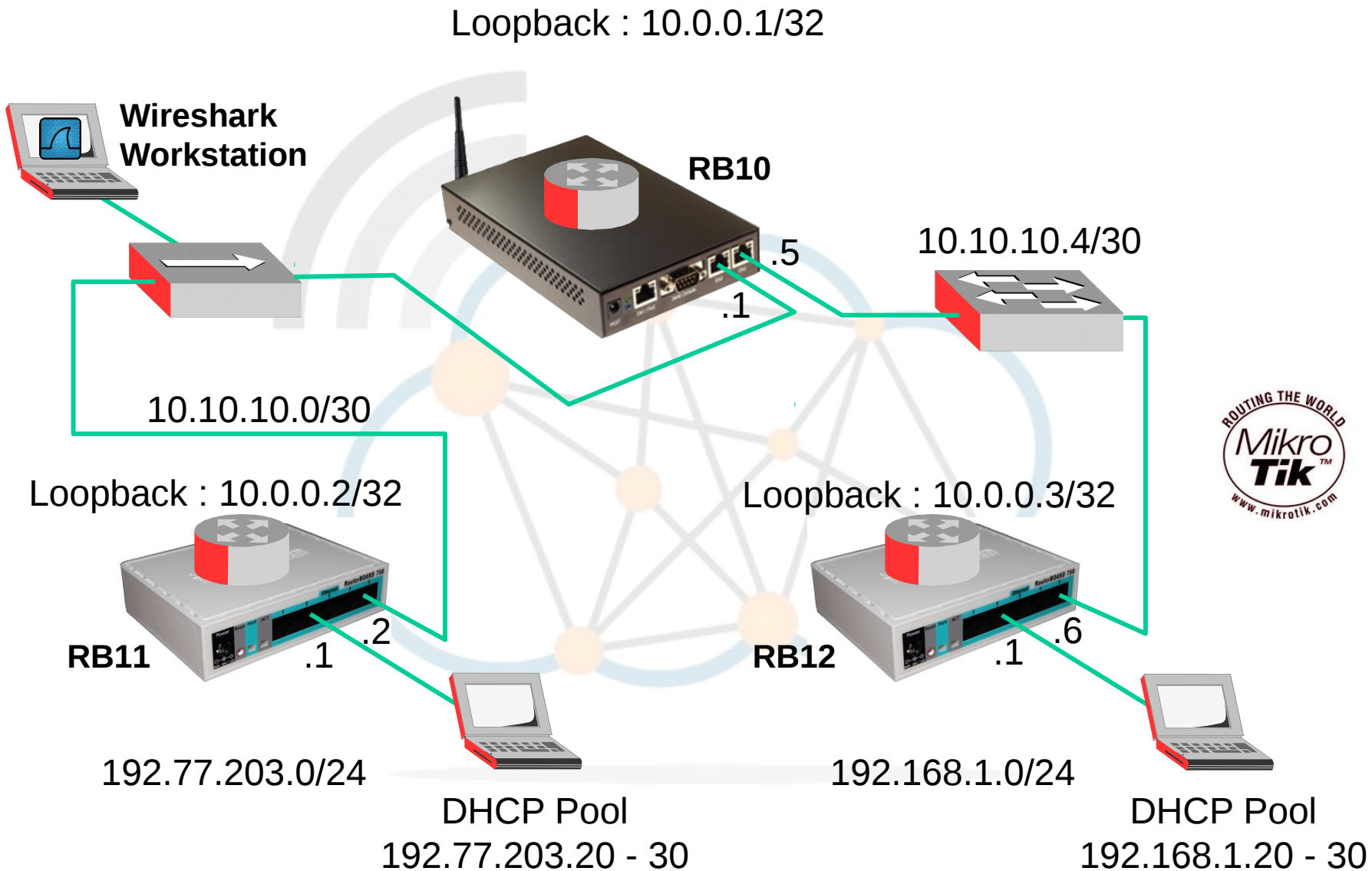



# Thank you

**Diarmuid Ó Briain**

CEng, FIEI, FIET, CISSP

diarmuid@obriain.com